

## FEATURES & BENEFITS

### CONSTRUCTION

16 gauge stainless steel booth and piping provides a solid free standing enclosed environment for added privacy and stability. Unit also comes equipped with integral 4" waste drain for proper waste water drainage.

### EYE/FACE WASH HEAD

AXION® MSR stainless steel eye/face wash head uses an inverted directional laminar flow to sweep contaminants away from the vulnerable nasal cavity.

### SHOWERHEAD

AXION® MSR stainless steel drench showerhead uses a hydrodynamic design to give equal distribution of water throughout the entire footprint of flow.

### VALVES

Eye/face wash activation occurs with a simple pull of the eyewash bend, and shower ball valve with a pull of the handle. Eyewash valve comes equipped with long lasting o-ring seals. Shower valve comes equipped with stainless steel ball and stem to provide greater protection against corrosion and breakage.

## OPTIONS

- Universal Drain Pan: Model 8605SS Config STD-UD provides drainage customization by offering the standard 8605SS shower/eyewash booth with a 4" floor drain and 3 1-1/2" drain ports on 3 sides. Plugs for unused drain ports are provided.
- Thermostatic Mixing Valve: Model 9201E AXION® Emergency Tempering Valve thermostatically mixes hot and cold water to provide a safe fluid supply for emergency showers and eyewash equipment, with a flow rate of 31 gpm (117.3 L).
- Emergency Alarm System: Model 9001, 1-1/4" 120 VAC emergency alarm and light system. Buzzer and flashing light are activated by an 1-1/4" double pole, double throw flow switch.
- Weekly test tag, SP170, green waterproof test card with space for date and initials of inspector. Used to record weekly testing of emergency equipment.

For more information, visit [www.nges-sa.com](http://www.nges-sa.com) or call(+242)055048665.



## SPECIFICATIONS

Model 8605SS combination shower and stainless steel eye/face wash stainless steel booth shall include an AXION® MSR stainless steel eye/face wash head with inverted directional laminar flow which achieves Zero Vertical Velocity™ supplied by an integral 3.7 gpm (14 L) flow control. Unit shall also include the AXION MSR hydrodynamic designed stainless steel showerhead with 20 gpm (75.7 L) flow control, stainless steel stay-open shower ball valve equipped with stainless steel ball and stem supplied by stainless steel piping, pull-down activated eye/face wash, 16 gauge Type 304 Stainless Steel booth, fiberglass reinforced plastic floor grate, heavy-duty modesty curtain, universal signs, 1" NPT top or bottom supply, and 4" integral NPTF floor drain.

## APPLICATIONS

Where the eyes, face, or body of any person may be exposed to injurious or corrosive materials, suitable facilities for quick drenching or flushing of the eyes, face, and body shall be provided within the work area for immediate emergency use. Emergency eye/face wash facilities and deluge showers shall be in unobstructed and accessible locations that require no more than 10 seconds for the injured person to reach. Model 8605SS is certified by CSA to meet the ANSI/ISEA Z358.1 Standard for Emergency Eyewash and Shower Equipment.

NOTES:

1. WHEN INSTALLING THIS UNIT, LOCAL, STATE, OR FEDERAL CODES SHOULD BE ADHERED TO FOR INSTALLATIONS (LOCATIONS), WASTE AND SUPPLY REQUIREMENTS OTHER THAN SHOWN.
2. KEEP ENTRY WAY AND INSIDE OF BOOTH CLEAR OF OBSTRUCTIONS.
3. DIMENSION MAY VARY  $\pm 1/2"$ .

(NOTES CONTINUED ON SHEET 2)

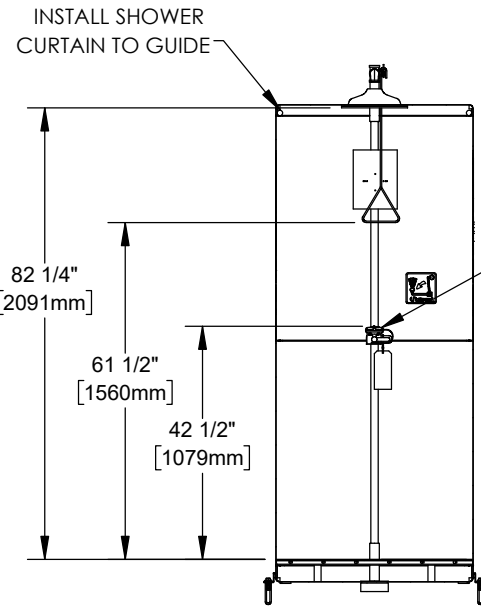
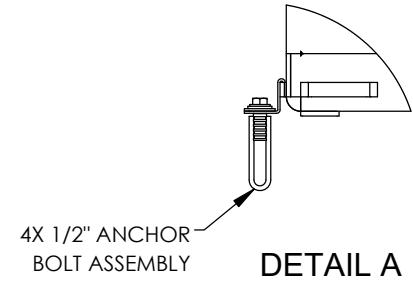
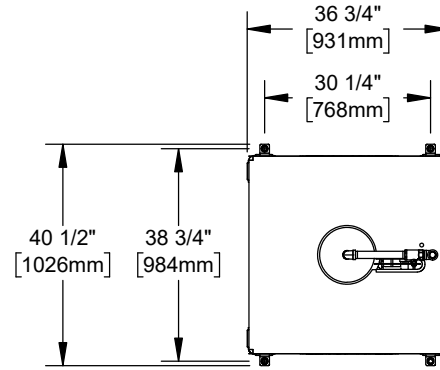

SECTION B-B

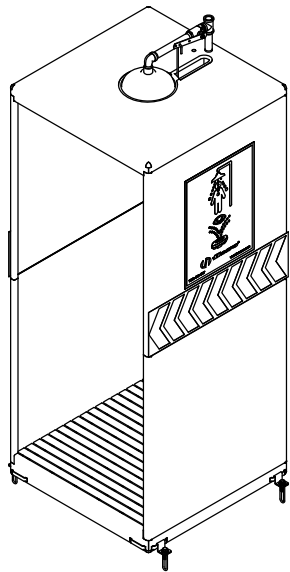
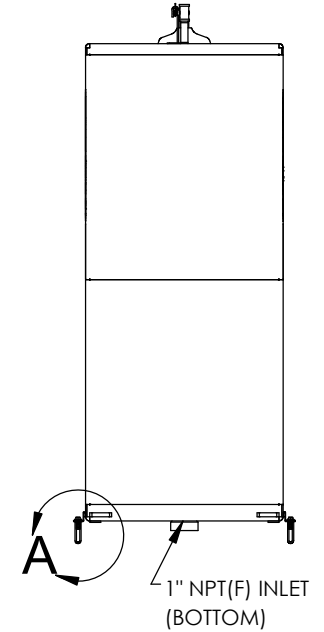
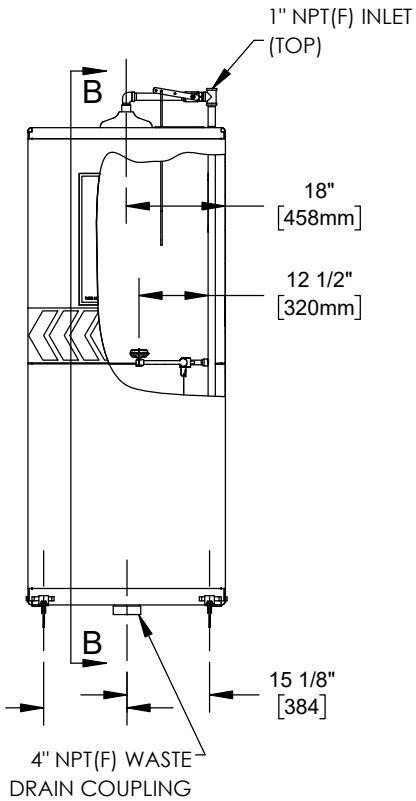

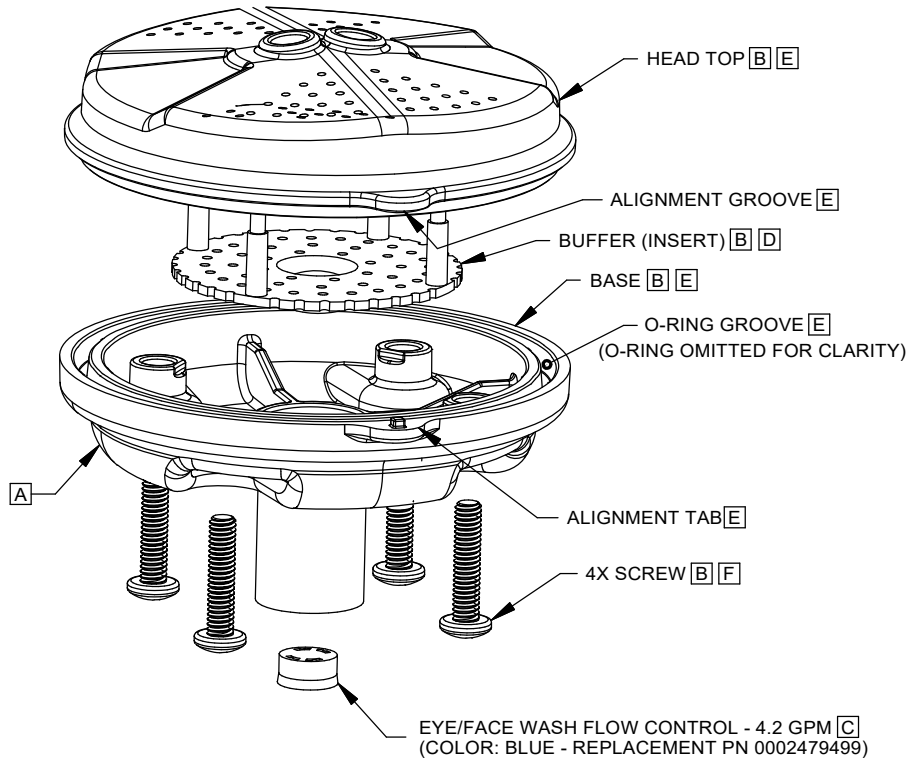

**Haws**<sup>®</sup>  
 Since 1906

ECN: 5940	REV. ECN: 6109	BY: FV	MODEL(S) 8605SS SINGLE ENTRY STAINLESS STEEL BOOTH	PART NUMBER 0580002177.D
DRAWN: IR	DATE: 07/11/23	CHKD: KM	REVISION 2	
APPROVED:	DATE:			A SHEET 1 OF 2

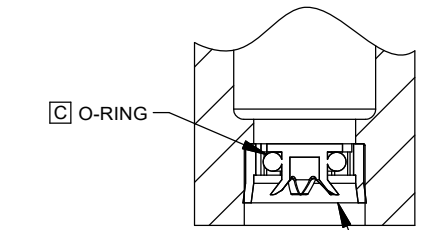

4. FLOW CONTROL CLEANING STEPS:

- [A] UNSCREW EYE/FACE WASH ASSEMBLY FROM ADAPTER (NOT SHOWN FOR CLARITY).
- [B] REMOVE SCREWS (QTY. 4) FROM EYE/FACE WASH ASSEMBLY IN ORDER TO SEPARATE EYE/FACE WASH HEAD TOP FROM THE BASE AND REMOVE BUFFER (INSERT).
- [C] REMOVE EXISTING FLOW CONTROL FROM BASE BY PUSHING IT OUT FROM THE TOP AND CAREFULLY REMOVE ANY DEBRIS LODGED BETWEEN O-RING AND HOUSING OR OPENINGS. ALSO, CHECK FOR ANY SEDIMENT OR MINERAL DEPOSITS BLOCKING OPENINGS. EXERCISE CAUTION NOT TO DAMAGE OR LOSE O-RING IN THE PROCESS. ALL OPENINGS ON FLOW CONTROL MUST BE FREE AND CLEAR OF ANY OBSTRUCTIONS FOR FLOW CONTROL TO FUNCTION PROPERLY. REINSTALL FLOW CONTROL. SEE **DETAIL A** FOR ORIENTATION.
- [D] REINSERT BUFFER (INSERT) INTO EYE/FACE WASH HEAD NOTING ORIENTATION OF POST IN RELATIONSHIP TO L-SHAPED RIB AS SHOWN ON **DETAIL B**.
- [E] REASSEMBLE EYE/FACE WASH HEAD, MAKING SURE THAT ALIGNMENT GROOVE ON EYE/FACE WASH HEAD LINES UP WITH ALIGNMENT TAB ON BASE & O-RING IS SEATED IN O-RING GROOVE.
- [F] REINSTALL SCREWS (QTY. 4) INTO THE EYE/FACE WASH HEAD ASSEMBLY AND TIGHTEN SNUG ENSURE A WATER-TIGHT SEAL.
- [G] REASSEMBLE EYE/FACE WASH ASSEMBLY (TAB ORIENTED TOWARDS THE BOTTOM IN CLOSED POSITION) - DO NOT OVER-TIGHTEN. PLACE DUST COVER OVER EYE/FACE WASH HEAD.



FLOW CONTROL SHOWN IN PLACE  
NOTE: PRESS FLOW CONTROL IN  
UNTIL IT BOTTOMS OUT

[C] **DETAIL A**

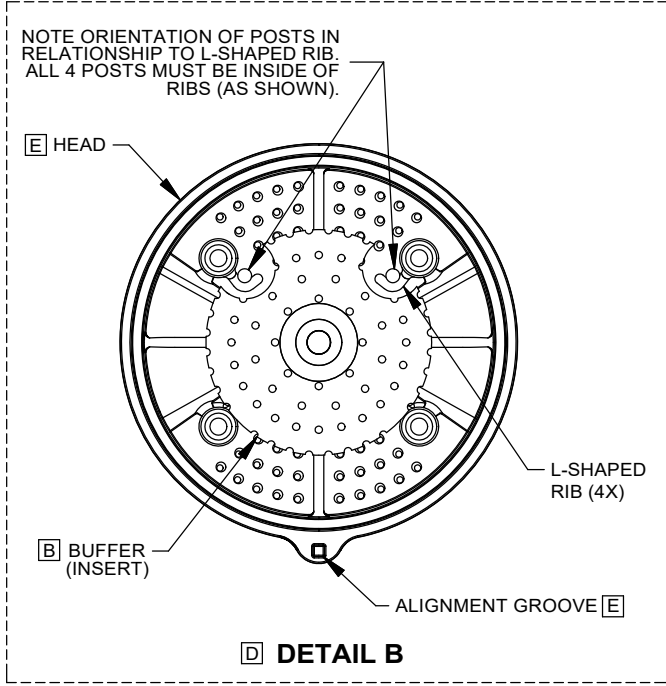
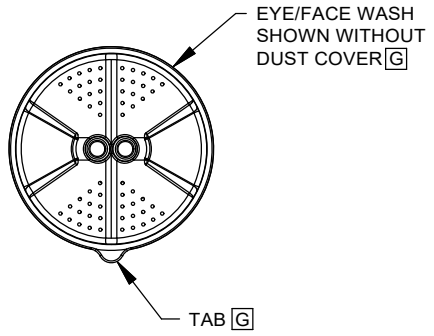

[D] **DETAIL B**

ECN: 5940	REV. ECN: 6109	BY: FV	MODEL(S)	PART NUMBER
DRAWN: IR	DATE: 07/11/23	CHKD: KM	8605SS SINGLE ENTRY STAINLESS STEEL BOOTH	0580002177.D
APPROVED:	DATE:			REVISION
				2
				SHEET 2 OF 2